

# 1935-1936 Ford Ignition Lock Assembly

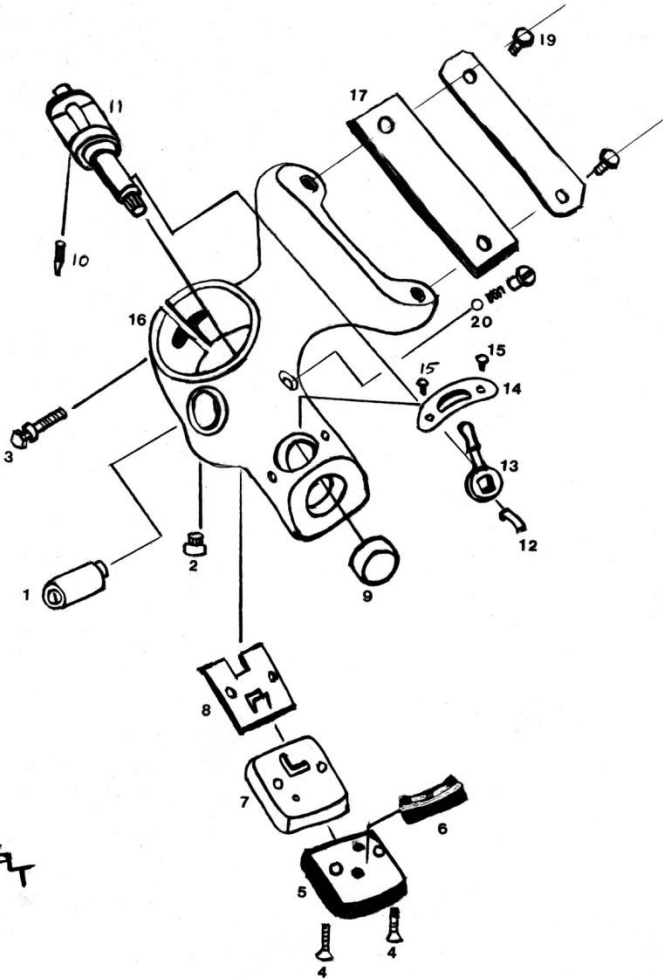

## 1935-1936 Ford Ignition Lock Parts Listing

### Number Description

- 1 Lock cylinder
- 2 Lock cylinder pin (serrated press-fit)
- 3 Break-off bolt to secure housing to steering tube
- 4 Screws to attach switch to housing
- 5 Switch plate
- 6 Switch contacts
- 7 Switch housing
- 8 Guide plate for switch lever
- 9 End cap (serrated press-fit)
- 10 On-off lever pin to move switch contacts
- 11 Locking steering wheel plunger
- 12 Spring for lever to maintain tight fit to plunger
- 13 On-off lever
- 14 On-off switch indicator (35&36 On is down Off is up)
- 15 Screw type rivets to attach switch indicator plate to housing
- 16 Ignition lock housing
- 17 Rubber material between housing and dash
- 18 Steel plate between bolts and dash
- 19 Steel attaching bolt for housing to dash
- 20 Switch position detent ball, spring and cap to hold switch position

# "REBUILDING A 1935-36 STEERING COLUMN IGNITION/LOCK MECHANISM"

1. Remove the ignition lock mechanism and steering column from car. Please note that left bolt **A** is twist-off type and will have to be removed with vice grips.

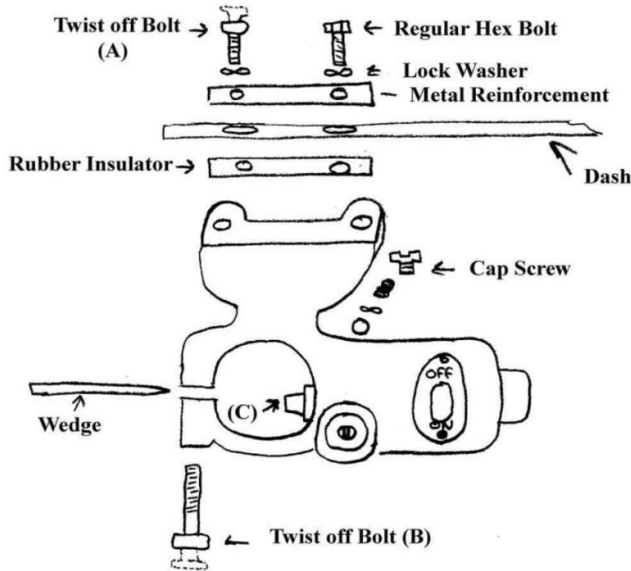

2. If the ignition/lock mechanism is still attached to the steering column, it can only be removed after twist-bolt **B** is removed. Drilling screw blade slot in head is easiest way to do that.  Twist Bolt Head
3. Remove cap screw, washer, spring, and ball bearing from top rear part of casting.
4. If the ignition lock has a working key and cylinder, turn the key counter-clockwise to fully retract column locking mechanism. **C**

**Note:** If the key is lost or the cylinder is jammed, the set pin must be removed (drilled out) on bottom of lock mechanism. A hole can be drilled 3/8" into casting without destroying the cylinder. The cylinder should now be able to be turned or jiggled until it can be pulled out. The locking mechanism can now be retracted.

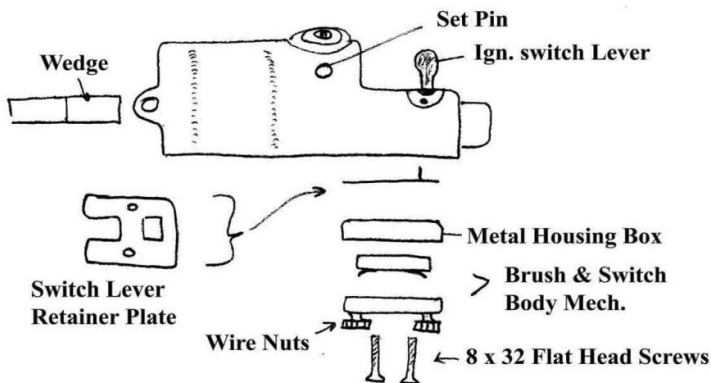

The steering column can now be removed. A wedge driven into gap in ignition lock collar should help.

5. Now is as good a time as any to remove the ignition electrical switch assembly. Two screws hold the switch lever retainor plate, metal housing box, and switch body and brush in place.

**Note:** Most restorations leave out the switch lever retainer plate. This is a very important part that helps keep the switch lever aligned.

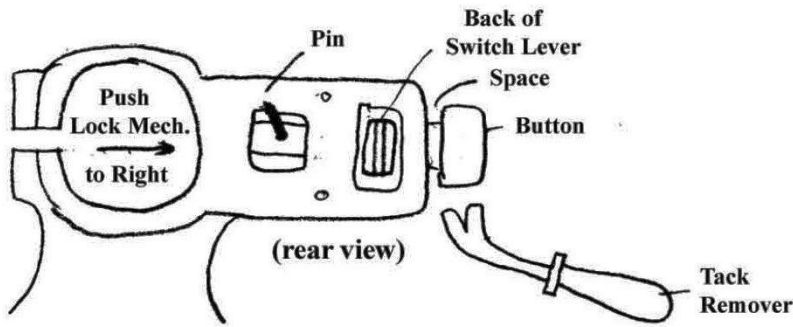

it pops off the locking mechanism.

6. Next, remove the pin from the locking mechanism slide.

7. Push the lock mechanism slide all the way to the right so a space appears under the slide button. Gently pry up on the button in a circular motion until

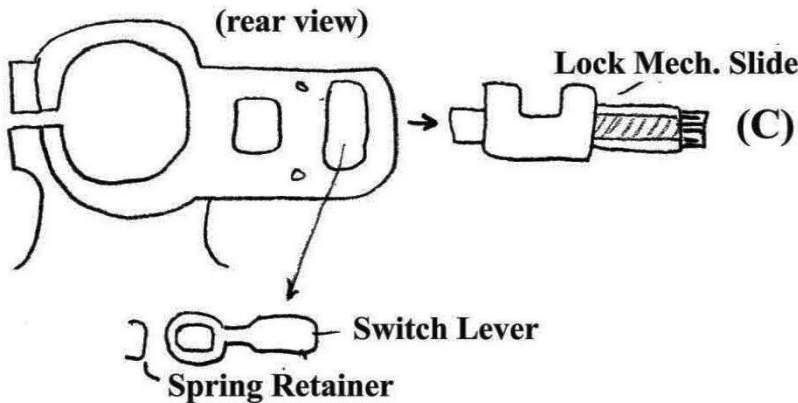

8. Using a tack remover or similar device on the rivets, remove the "On-Off" nameplate from the front of the lock mechanism body. This must be removed before the switch lever can be removed.

9. Now push the locking mechanism slide all the way to the left. This allows the switch lever to be removed. Push the locking mechanism slide to the right to remove it.

**Note:** The switch lever has spring retainer. This keeps tension on the lever.  
**Don't lose it!**

10. The following should be done prior to reassembly:

- a. Soak locking mechanism slide in WD40 to loosen (Don't Plate)
- b. Chrome plate - the slide button, ignition switch lever, and cap screw
- c. Cadmium plate - the electrical switch metal housing box and switch lever retainer plate
- d. Tap out set pin hole on bottom of housing to accommodate 5/16" coarse thread. Get 5/16" x 1/4" set screw. (I find this preferable to using a set pin)
- e. Paint housing to match steering column. Dark Taupe Enamel (35 deluxe), Black Enamel (35 & 36 standard), Benton Grey (Early 36 deluxe) & Russet Brown (late 36 deluxe)
- f. Get (2) twist-off bolts.

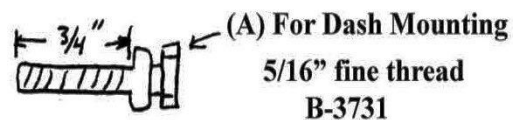
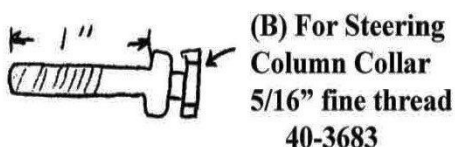

- g. Get new lock cylinder or rehabilitated old one.
- h. Get new switch nameplate.
- i. Get new bakelite switch and brush.

11. Reassemble as follows:
  - Lock mechanism into housing.
  - Switch lever and spring retainer (make sure hole for pin on lock mechanism facing out).
  - Gently tap button on to lock mechanism.
  - Replace pin in lock mechanism.
  - Put lock cylinder (1) in place and fasten with set screw.
  - Put nameplate in place with rivets.
  - Reassemble switch and brush housing and spacer with 8 x 32 screws.
  - Replace cap screw, spring, lock washer, and ball bearing.
  - Test mechanism.
12. Completed mechanism can be put onto steering column by spreading collar with wood wedge, putting wax paper on column, and sliding mechanism into place - Put twist-off bolt into collar. Do not tighten till the column is in the car.
13. Remember to use rubber spacer, (1) twist-off bolt, and (1) regular bolt and metal reinforcer strip when attaching to dash!

Footnote (1): Lock cylinders differ from 35 to 36.



**Round 1935-36 ignition key**



**1935**



**1936**

That's It!

Don Rogers